



Western Australian Certificate of Education Examination, 2015

Question/Answer Booklet

ENGINEERING STUDIES

Stage 3

Please place your student identification label in this box

Student Number: In figures

--	--	--	--	--	--	--	--

In words

Time allowed for this paper

Reading time before commencing work: ten minutes
Working time for paper: three hours

Materials required/recommended for this paper

To be provided by the supervisor

This Question/Answer Booklet
Multiple-choice Answer Sheet
Data Book

Place a tick (✓) in one of the following boxes to indicate your specialist field.

Systems and Control	<input type="checkbox"/>
Mechanical	<input type="checkbox"/>
Electronic/Electrical	<input type="checkbox"/>

Number of additional answer booklets used (if applicable):	<input style="width: 40px; height: 20px;" type="text"/>
--	---

To be provided by the candidate

Standard items: pens (blue/black preferred), pencils (including coloured), sharpener, correction fluid/tape, eraser, ruler, highlighters

Special items: non-programmable calculators approved for use in the WACE examinations

Important note to candidates

No other items may be taken into the examination room. It is **your** responsibility to ensure that you do not have any unauthorised notes or other items of a non-personal nature in the examination room. If you have any unauthorised material with you, hand it to the supervisor **before** reading any further.

STAGE 3

Structure of this paper

Section	Number of questions available	Number of questions to be answered	Suggested working time (minutes)	Marks available	Percentage of exam
Section One: Core content					
Part A: Multiple-choice	10	10	70	10	10
Part B: Extended answer	3	3		45	30
Section Two: Systems and control					
Part A: Multiple-choice	10	10	110	10	10
Part B: Extended answer	4	4		100	50
Section Two: Mechanical					
Part A: Multiple-choice	10	10	110	10	10
Part B: Extended answer	5	5		100	50
Section Two: Electronic/electrical					
Part A: Multiple-choice	10	10	110	10	10
Part B: Extended answer	5	5		100	50
Total					100

Instructions to candidates

- The rules for the conduct of Western Australian external examinations are detailed in the *Year 12 Information Handbook 2015*. Sitting this examination implies that you agree to abide by these rules.
- Section One: You must answer **all** questions.
Section Two: You must choose to answer only **one (1)** of the specialist fields. In the specialist field you have chosen, answer **all** questions.
In both Section One and Section Two, answer the questions according to the following instructions.
Part A: Multiple-choice
Answer **all** questions on the separate Multiple-choice Answer Sheet provided. For each question, shade the box to indicate your answer. Use only a blue or black pen to shade the boxes. If you make a mistake, place a cross through that square, then shade your new answer. Do not erase or use correction fluid/tape. Marks will not be deducted for incorrect answers. No marks will be given if more than one answer is completed for any question.
Part B: Extended answer
Answer **all** questions. Write your answers in the spaces provided in this Question/Answer Booklet.
- You must be careful to confine your responses to the specific questions asked and to follow any instructions that are specific to a particular question.
- Spare pages are included at the end of this booklet. They can be used for planning your responses and/or as additional space if required to continue an answer.
 - Planning: If you use the spare pages for planning, indicate this clearly at the top of the page.
 - Continuing an answer: If you need to use the space to continue an answer, indicate in the original answer space where the answer is continued, i.e. give the page number. Fill in the number of the question that you are continuing to answer at the top of the page.
- The Data Book is **not** to be handed in with your Question/Answer Booklet.

See next page

Section One: Core content**40% (55 Marks)**This section has **two (2)** parts.Part A: Multiple-choice Answer **all** questionsPart B: Extended answer Answer **all** questions

Suggested working time: 70 minutes.

Part A: Multiple-choice**10% (10 Marks)**

This part has **10** questions. Answer **all** questions on the separate Multiple-choice Answer Sheet provided. For each question, shade the box to indicate your answer. Use only a blue or black pen to shade the boxes. If you make a mistake, place a cross through that square, then shade your new answer. Do not erase or use correction fluid/tape. Marks will not be deducted for incorrect answers. No marks will be given if more than one answer is completed for any question.

1. 5550 J of energy was required to raise a box a total height of 40 m in 500 s. Assuming that the motor was 90% efficient, what was the energy input to the motor?

- (a) 4995 J
- (b) 6167 J
- (c) 2 775 000 J
- (d) 3 083 333 J

2. A 5 kg ball rolls down from the top of slope AB, 5 m above the ground. It then rolls up slope CD. Slope AB is twice as steep as slope CD. What is the value of h when the ball finally comes to a stop along slope CD? Assume that the system is 100% efficient.

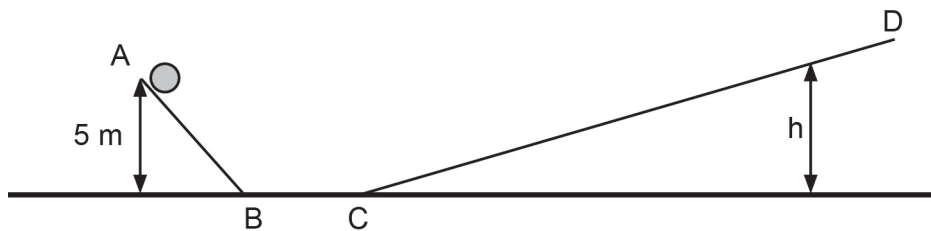

- (a) 2.5 m
 - (b) 5.0 m
 - (c) 7.5 m
 - (d) 10.0 m
3. Identify the non-renewable source of energy.
- (a) geothermal
 - (b) photovoltaic
 - (c) biomass
 - (d) nuclear

4. A 480 W floodlight operating on a 240V supply draws 2.0 A of current for one hour. What is the amount of energy used?
- (a) 120 J
 - (b) 480 J
 - (c) 432 000 J
 - (d) 1 728 000 J
5. Which of the following lists contains **only** non-ferrous materials?
- (a) solder, reinforced concrete, brass, polypropylene
 - (b) cast iron, acrylic, stainless steel, zinc
 - (c) brass, solder, acrylic, nylon
 - (d) stainless steel, aluminium, copper, zinc
6. Mobile phones that are still functional are frequently replaced by owners who want smarter phones with more features. Which of the following is the **most** environmentally friendly method of disposal?
- (a) taking the phone to a collection point for recycling of the metals and plastics
 - (b) taking the battery to a collection point before placing the phone in an incinerator
 - (c) waterproofing the phone in plastic before placing it in household rubbish
 - (d) selling the phone online or giving it to a family member
7. In the life cycle of an engineered product, the stages that precede manufacture are
- (a) material acquisition and processing materials.
 - (b) designing and packaging.
 - (c) prototyping and transporting.
 - (d) testing and planning.
8. When evaluating a new product, a manufacturer must give primary importance to
- (a) how the product should be marketed.
 - (b) providing detailed instructions to prevent misuse.
 - (c) safety, function and finish of the product.
 - (d) packaging, to prevent damage in transport.
9. Street lighting is connected to an electrical grid powered by a nuclear power station. The sequential transfer of forms of energy is
- (a) nuclear, electrical, thermal, electromagnetic.
 - (b) nuclear, thermal, kinetic, electrical, electromagnetic.
 - (c) nuclear, electro-chemical, light.
 - (d) nuclear, chemical, thermal, electrical, light.

10. The mass of an object can be found by
- (a) multiplying the density by the volume.
 - (b) dividing the density by the volume.
 - (c) dividing the volume by the density.
 - (d) comparing its volume with a known material.

Section One: Core content

Part B: Extended answer

30% (45 Marks)

This section has **three (3)** questions. Answer **all** questions. Write your answers in the spaces provided.

Spare pages are included at the end of this booklet. They can be used for planning your responses and/or as additional space if required to continue an answer.

- Planning: If you use the spare pages for planning, indicate this clearly at the top of the page.
- Continuing an answer: If you need to use the space to continue an answer, indicate in the original answer space where the answer is continued, i.e. give the page number. Fill in the number of the question that you are continuing to answer at the top of the page.

Question 11

(14 marks)

Renewable energy is seen as the answer to the growing problems associated with using fossil fuels.

- (a) Explain the term 'renewable energy'. (2 marks)

- (b) State **two** major problems that fossil fuels create. (2 marks)

One: _____

Two: _____

- (c) The generation of large amounts of power using renewable energy causes some problems. Outline briefly **two** of these problems. (4 marks)

One: _____

Two: _____

- (d) We are realising that we cannot solve the energy issues just by replacing fossil fuels with renewable sources. We need to look at reducing energy consumption. Outline briefly **two** major technological innovations that can help to reduce energy consumption. (4 marks)

One: _____

Two: _____

- (e) In deciding among different methods of generating renewable energy, ongoing maintenance should be considered. Solar panels require less maintenance than wind turbines or wave-generated energy. Why? (2 marks)

Question 12

(15 marks)

(a) By considering the physical properties of materials you have studied, give **two** reasons why each of the following materials is used for the stated applications.

(i) Solder is used in electrical circuit construction. (2 marks)

One: _____

Two: _____

(ii) Stainless steel is used to manufacture fittings on yachts and boats. (2 marks)

One: _____

Two: _____

(iii) Steel sheet is used to manufacture panels of motor vehicles. (2 marks)

One: _____

Two: _____

(iv) Copper is used to manufacture the wire in electrical extension cords. (2 marks)

One: _____

Two: _____

- (v) Nylon is used in fishing line. (2 marks)

One: _____

Two: _____

- (b) Stainless steel is an alloy.

- (i) Explain what an 'alloy' is. (1 mark)

- (ii) List **two** alloys having higher electrical conductivity than cast iron. (2 marks)

One: _____

Two: _____

- (c) The floors of multi-story buildings are constructed using reinforced concrete.

- (i) What is reinforced concrete? (1 mark)

- (ii) What is the purpose of reinforcing concrete? (1 mark)

Question 13

(16 marks)

- (a) A centre punch is used to create an indentation in metal that is to be drilled. The punch is hit by a hammer to create the indentation in which the drill bit will rest during the initial rotation of the drill. Consider the manufacture of the punch below.

The punch is made from a single cylinder of stainless steel 18 cm long and 1.6 cm in diameter.

- (i) Calculate the volume of the stainless steel cylinder before machining. Show **all** workings, and give your answer in cubic centimetres (cm³). (2 marks)

- (ii) Calculate the mass of stainless steel in the cylinder before machining. Show **all** workings, and give your answer in kilograms to three decimal places. Note: If unsure of your answer to part (i) above, use 40 cm³ for the volume. (2 marks)

The diagram below shows the punch after machining. The finished diameter of the punch is 1.4 cm, the conical end is 5 cm long **through its centre** and the cylindrical section is 12 cm long.

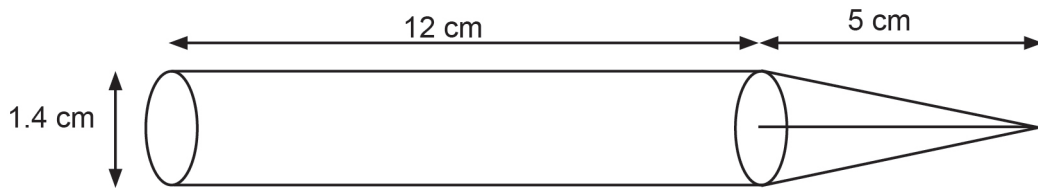

- (iii) The volume of a cone can be calculated using the formula $V = \frac{\pi r^2 h}{3}$, where r is the radius of the cone and h is the height through the centre. Calculate the volume of the **conical** section of the punch. Show **all** workings, and give your answer in cubic centimetres (cm³). (2 marks)

- (iv) Calculate the length of the side of the cone. Show **all** workings, and give your answer in centimetres to three decimal points. (2 marks)

Question 13 (continued)

- (v) Calculate the total volume of the punch. Show all workings, and give your answer in cubic centimetres (cm^3). Note: If unsure of your answer to part (iii), use 3 cm^3 for the volume of the cone. (2 marks)

- (vi) Give **two** reasons why steel must be hardened when it is to be used in a tool such as this. (2 marks)

One: _____

Two: _____

(b) A sloping patio roof with the dimensions shown below is to be painted.

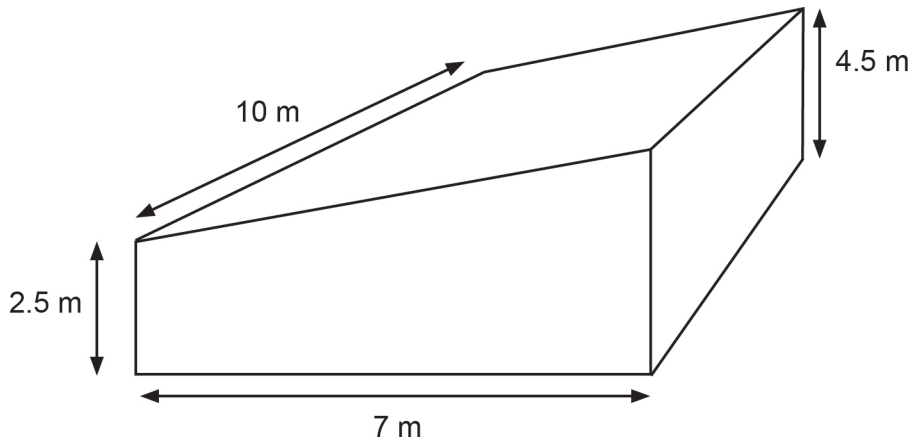

(i) Calculate the area of the roof. Show **all** workings, and give your answer in square metres (m^2). (2 marks)

(ii) Calculate the minimum volume of paint required to provide the roof with a layer of paint 0.3 mm thick. Show **all** workings, and give your answer in litres (L) using $1 m^3 = 10^3 L$. Note: If unsure of your answer to part (i) above, use $75 m^2$. (2 marks)

End of Section One

See next page

This page has been left blank intentionally

See next page

Section Two: Specialist fields**60% (110 Marks)**

Candidates are required to choose **one** of the following options, according to the specialist field they studied in 2015.

Tick one of the boxes below to indicate your choice of option.

Specialist field	✓	Question numbers	Pages
Systems and control	<input type="checkbox"/>	14–27	16–31
Mechanical	<input type="checkbox"/>	28–42	32–48
Electronic/electrical	<input type="checkbox"/>	43–57	49–65

Now turn to the relevant pages and answer the questions for the specialist field you have selected.

See next page

Section Two: Specialist field—Systems and Control

60% (110 Marks)

This section has **two (2)** parts.

Part A: Multiple-choice Answer **all** questions

Part B: Extended answer Answer **all** questions

Suggested working time: 110 minutes.

Part A: Multiple-choice

10% (10 Marks)

This part has **10** questions. Answer **all** questions on the separate Multiple-choice Answer Sheet provided. For each question, shade the box to indicate your answer. Use only a blue or black pen to shade the boxes. If you make a mistake, place a cross through that square, then shade your new answer. Do not erase or use correction fluid/tape. Marks will not be deducted for incorrect answers. No marks will be given if more than one answer is completed for any question.

14.

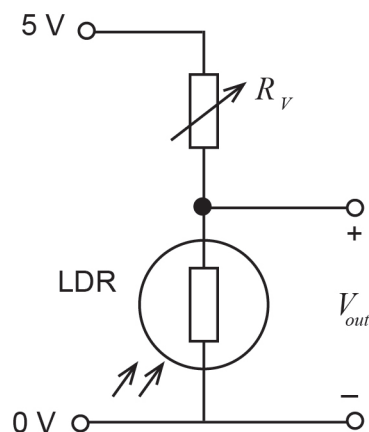

In order for the circuit shown above to control a lighting system, the V_{out} should be connected to the

- (a) analogue input pin of the PICAXE microcontroller.
 - (b) analogue output pin of the PICAXE microcontroller.
 - (c) digital input pin of the PICAXE microcontroller.
 - (d) digital output pin of the PICAXE microcontroller.
15. Microcontrollers run a user program that allows them to perform their tasks. Which sub-unit of the microcontroller would this be stored in?
- (a) Central Processing Unit (CPU)
 - (b) Read Only Memory (ROM)
 - (c) Random Access Memory (RAM)
 - (d) Electrically Erasable Programmable Read Only Memory (EEPROM)

See next page

16. Which of the following shows a closed loop system with two inputs?

(a)

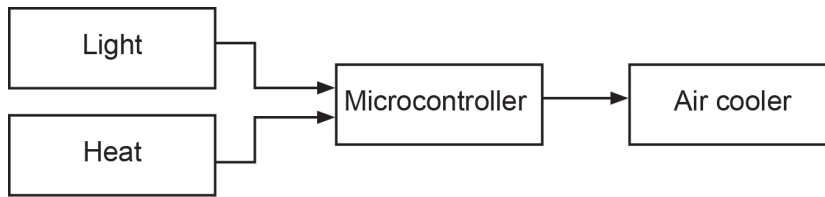

(b)

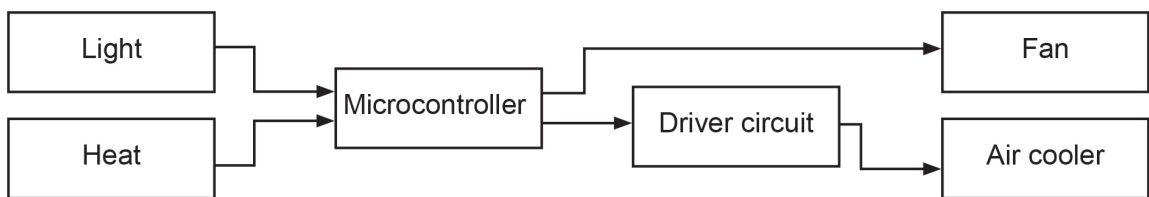

(c)

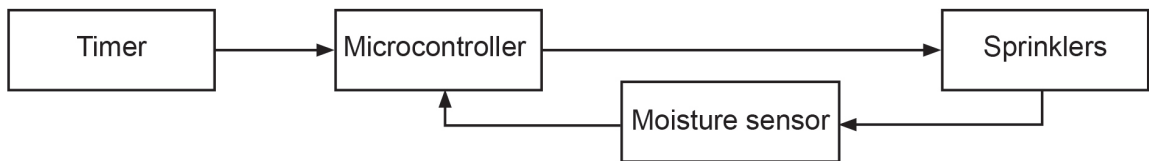

(d)

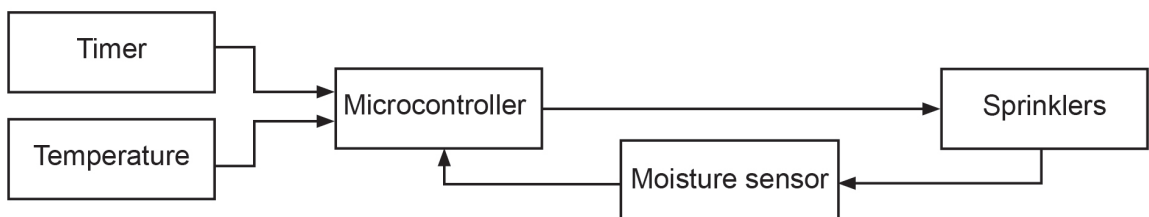

17. Servos generate a lot of electrical noise. When interfacing with sensitive electronics which of the following measures does **not** help to reduce or isolate this noise?
- (a) using a lower voltage on the power supply line
 - (b) using a separate power supply for the servos
 - (c) using decoupling capacitors between the power supply to ground
 - (d) using a diode on the DC power lines
18. An analog value of 4.00 V measured on a 10 bit ADC connected to a 5.00 V supply will have a precision of
- (a) 0.000781 V.
 - (b) 0.00488 V.
 - (c) 0.08 V.
 - (d) 0.8 V.

19. What is the Boolean expression associated with the output, Q, of the two gates shown below?

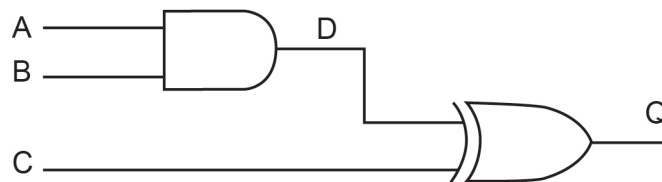

- (a) $Q = A.B.C.D$
 - (b) $Q = A.B.(C+D)$
 - (c) $Q = (A.B) \oplus C$
 - (d) $Q = (A.B) \oplus (C+D)$
20. A system is designed such that the output is HIGH **only if both** its inputs are LOW. Which of the following gates can be used to implement the above logic?
- (a) AND gate
 - (b) NAND gate
 - (c) XOR gate
 - (d) NOR gate

21. The drive shaft of an engine turns at 4000 rpm. The drive shaft engages with a gearbox with a velocity ratio of 3.2. The output of the gearbox is then sent to the final transfer case and the output emerges with an rpm of 500. What is the velocity ratio of the transfer case?

- (a) 1
- (b) 12
- (c) 5.3
- (d) 25.6

22. In the tower crane shown below, both the effort and the load can move along their respective arms to keep the crane balanced. What is the minimum mechanical advantage of the crane when the effort is at the end of the 4 m effort arm as shown?

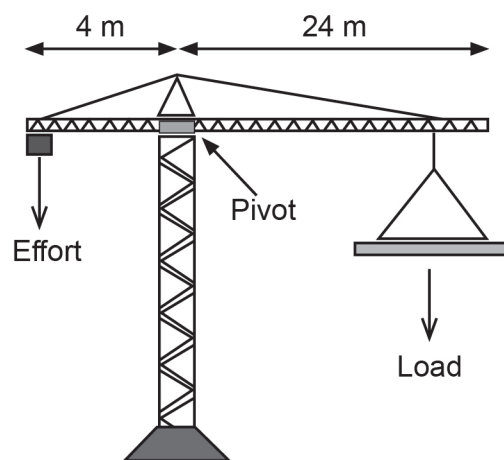

- (a) 0.167
- (b) 1
- (c) 6
- (d) 96

23. A worm gear drive system locks into place when the power is switched off. Why is this so?

- (a) Only the powered worm gear can be used to drive the system.
- (b) The system has high inertia.
- (c) It is able to transmit large forces.
- (d) Large increases in velocity can be achieved in a small space.

Part B: Extended answer

50% (100 Marks)

This part has **four (4)** questions. Answer **all** questions. Write your answers in the spaces provided.

Spare pages are included at the end of this booklet. They can be used for planning your responses and/or as additional space if required to continue an answer.

- Planning: If you use the spare pages for planning, indicate this clearly at the top of the page.
- Continuing an answer: If you need to use the space to continue an answer, indicate in the original answer space where the answer is continued, i.e. give the page number. Fill in the number of the question that you are continuing to answer at the top of the page.

Question 24

(29 marks)

At a bank, a vault is used to store money and valuables. The vault is protected by an alarm system. When switched on, it monitors the status of the key lock, the fingerprint sensor and the door of the vault. The door can only be opened safely if the key lock has been deactivated and the fingerprint sensor has successfully recognised the authorised fingerprint. If the door of the vault is opened when the key lock is still active or the fingerprint sensor has not detected a match, a siren sounds at the bank and a LED at the security post lights up.

When the alarm is switched off, the LED lights up at the security post.

The inputs to the alarm system are as follows:

- SW1 is the signal from the alarm system. It is LOW when the alarm is switched off and HIGH when it is turned on.
- L1 is the signal from the key lock. L1 produces a HIGH when locked and a LOW when unlocked.
- F1 is the signal from the fingerprint sensor. It is usually in a HIGH state and produces a LOW only when a fingerprint is recognised.
- S1 is the sensor at the door of the vault. It produces a HIGH if the door is open and a LOW if it is closed.

The outputs to the alarm system are as follows:

- A1 is the signal that controls the siren. The siren is triggered when the signal is HIGH.
- E1 is the signal used to illuminate the LED. The LED is lit when the signal is HIGH.

- (a) Construct a Boolean logic expression to represent the operation of the LED at the security post, given the four inputs. (4 marks)

- (b) Draw a flow chart for the alarm system. Use the standard flow chart symbols shown in the **Data Book**. (11 marks)

Question 24 (continued)

- (c) Complete the truth table below. Use 1 to indicate True/ON and 0 to indicate False/OFF.
(8 marks)

Inputs				Outputs	
SW1	L1	F1	S1	A1	E1
0	0	0	0	0	1
0	0	0	1	0	1
0	0	1	0		
0	0	1	1	0	1
0	1	0	0	0	1
0	1	0	1		
0	1	1	0	0	1
0	1	1	1	0	1
1	0	0	0		
1	0	0	1	0	0
1	0	1	0	0	0
1	0	1	1		
1	1	0	0		
1	1	0	1		
1	1	1	0		
1	1	1	1		

- (d) Draw and label a logic diagram for the alarm system. You must use a combination of discrete logic gates and each gate should be drawn using the standard symbols. Each input and output signal must be labelled clearly to match the signals described in the question. (6 marks)

Question 25

(19 marks)

Many toy electric cars use microprocessors for their precise control. Consider a child's electric vehicle that uses a 12 V battery and has a PICAXE microcontroller.

- (a) Explain how pulse width modulation (PWM) can be used to control the speed of the electric car and why it is considered to be a good control technique. (7 marks)

- (b) Design an input voltage regulator circuit using a suitable voltage regulator component for the PICAXE microcontroller in the vehicle. Show all connections and any additional components clearly such that the input to the PICAXE is 5 V. (4 marks)

+12 V ●

0 V ●

PICAXE-14M

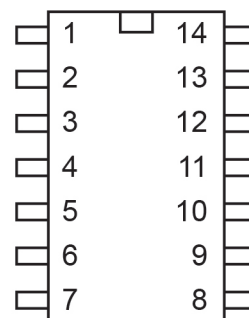

- (c) The output from the PICAXE is used to control a transistor with a 12 V DC relay that powers the vehicle's motor. Draw a suitable circuit, showing clearly how it connects to the PICAXE and the motor. (8 marks)

+12 V ●

0 V ●

PICAXE-14M

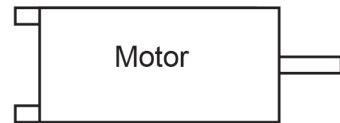
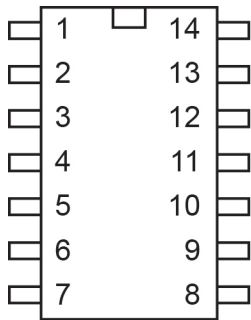

Question 26

(27 marks)

A washing machine uses a pulley-belt drive system, as shown below. This consists of a driver attached to a follower, using a rubber belt. The follower is attached to the drum with a drive shaft.

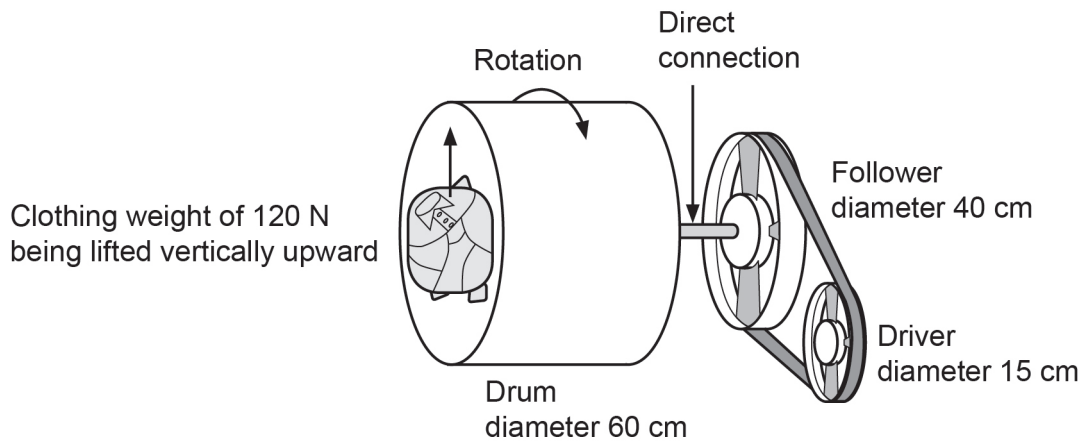

- (a) The drum of the washing machine spins at speeds of up to 900 revolutions per minute (rpm). Determine the maximum rpm of the driver. Show **all** workings. (6 marks)

(b) The machine is designed to handle a maximum load of 120 N of clothes. The clothes are gathered at the boundary of the drum and lifted vertically, as shown in the diagram. Assuming that the system has 100% efficiency, and showing **all** workings

(i) determine the torque developed by the drum. (3 marks)

(ii) Hence, determine the torque developed by the driver. (1 mark)

(c) State **two** reasons why the driver torque value found in (b)(ii) above is likely to be insufficient in a real-world system. (2 marks)

One: _____

Two: _____

(d) Find the minimum frictional force between the belt and the pulley required to ensure that the system is able to operate without slipping. Show **all** workings. (6 marks)

Question 26 (continued)

- (e) The manufacturer decides not to increase the minimum frictional force between the belt and the pulley. State the problem this may cause and explain why it can be viewed as both an advantage and a disadvantage. (3 marks)

Problem: _____

Advantage: _____

Disadvantage: _____

- (f) To overcome the disadvantages of using a pulley-belt drive system, the manufacturer changes the drive mechanism to a compound gear drive, as shown below. Determine the velocity of the driver if the manufacturer wishes to change the maximum rotation of the drum to 400 revolutions per minute. Show **all** workings. (6 marks)

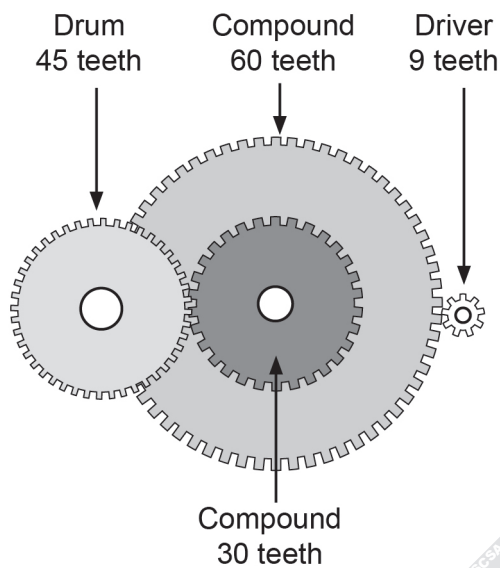

Question 27**(25 marks)**

Precious gemstones are polished by tumbling them in a small drum. The drum is connected to a small DC motor which is controlled by a microcontroller.

For effective washing, the speed of rotation of the drum must be matched to the mass of gems loaded into the drum. The mass of gems in the machine is measured by a mass sensor, which is connected to a microcontroller. This enables the gem polisher to start drum rotation at a nominal speed matched to the mass of gems. As the drum rotates, a vibration sensor continuously measures the vibration in the drum caused by the gems tumbling from T to B as shown in the diagram below.

To fine-tune the speed of the drum, the microcontroller slows down the rotation of the drum by about 20% and then slowly increases the speed while recording the vibration produced at each speed to select the speed with the greatest amount of vibration. When the correct speed is selected, the gems are lifted from the base of the rotating drum, B, and allowed to tumble down from the top, T. The arrows in the diagram below show the path of travel of the gems when the speed is matched correctly.

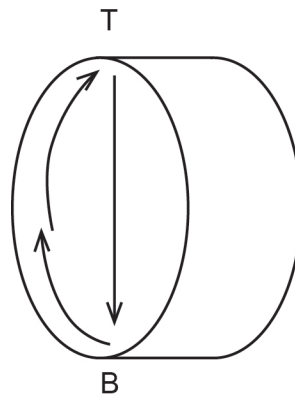

- (a) Sketch a block diagram with a microprocessor to include more than one input where one of these is a control sensor that is included in the feedback loop. (6 marks)

Question 27 (continued)

- (b) Draw a flow chart for the microprocessor, showing how the speed of rotation of the drum is initially set and fine-tuned. Use the standard flow chart symbols shown in the **Data Book**.

(13 marks)

- (c) Connect the mass sensor and vibration sensor to the microcontroller shown below using interfacing circuits. Earth the PICAXE and both sensors. Assume that the PICAXE is connected to a 5 V supply and insert a voltage dropping resistor where necessary.

The mass sensor provides an output of 2 V when the drum is empty and an output of 4.5 V when the drum is more than half filled.

The vibration sensor provides a range of values from 0 V to 6 V. (6 marks)

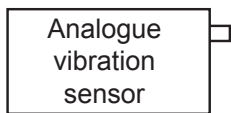

PICAXE-14M

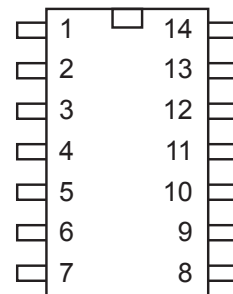

End of Section Two: Systems and Control

See next page

Section Two: Specialist field—Mechanical

60% (110 Marks)

This section has **two (2)** parts.

Part A: Multiple-choice Answer **all** questions

Part B: Extended answer Answer **all** questions

Suggested working time: 110 minutes.

Part A: Multiple-choice

10% (10 Marks)

This part has **10** questions. Answer **all** questions on the separate Multiple-choice Answer Sheet provided. For each question, shade the box to indicate your answer. Use only a blue or black pen to shade the boxes. If you make a mistake, place a cross through that square, then shade your new answer. Do not erase or use correction fluid/tape. Marks will not be deducted for incorrect answers. No marks will be given if more than one answer is completed for any question.

28. An object moving in a straight line with a constant velocity can be described as being in a state of
- (a) acceleration.
 - (b) zero gravity.
 - (c) instability.
 - (d) equilibrium.
29. How many kN m^{-2} are there in one MPa?
- (a) 1.00×10^3
 - (b) 1.00×10^{-3}
 - (c) 1.00×10^9
 - (d) 1.00×10^6
30. The unit usually used to measure power is the watt (W). One watt is equivalent to one
- (a) joule second.
 - (b) joule per second.
 - (c) newton second.
 - (d) newton per metre.

31. A ball possesses kinetic energy
- (a) when it is being held in your hand ready to be dropped.
 - (b) when you have just released your grip on it.
 - (c) when it is falling to the ground.
 - (d) after it has hit the ground and stopped.
32. Two forces, equal in magnitude, are applied to an object. Under which of the following conditions will these forces be in equilibrium?
- (a) They must be acting in opposite directions.
 - (b) They must be acting in the same straight line.
 - (c) They must be acting in the same direction.
 - (d) They must be acting at right angles to each other.
33. Pylons to support jetties are driven into the seabed using a pile driver. The pile is lifted mechanically to a predetermined height and then released to fall onto the top of the pylon. Which of the following energy conversions occurs while the pile is falling but before it comes to rest?
- (a) kinetic energy to potential energy
 - (b) mechanical energy to kinetic energy
 - (c) potential energy to kinetic energy
 - (d) potential energy to mechanical energy
34. When hot-rolled steel alloys are forced through dies to close dimensional tolerances, the end product is known as
- (a) stainless steel.
 - (b) bright drawn steel.
 - (c) cold drawn steel.
 - (d) pressed steel.
35. A hydro-electric power station can produce electrical energy at a rate of 50 kW when the speed of the waterfall is 5 m s^{-1} . If the efficiency of the generator is 50%, what force is exerted by the waterfall?
- (a) 2000 N
 - (b) 1500 N
 - (c) 1000 N
 - (d) 20 000 N

36. To produce machinery components from iron or steel, hot forging is commonly used as the preferred manufacturing process. Which of the following is a **disadvantage** of hot forging for this manufacturing process?

- (a) It produces components that are more easily machined.
- (b) It allows iron and steel to be more malleable.
- (c) The surface of the manufactured component will require further machining.
- (d) It cannot be used to produce multiple pieces of the same component.

37. In a car, the linkage that connects the accelerator to the carburettor consists of a metal plate of length 0.1 m pivoted at its centre and attached to the accelerator pedal via a metal rod at end A and to the carburettor via a metal cable at end B. When the plate is at an angle of 60° to the vertical, the rod from the foot pedal applies a torque of 2.5 N m.

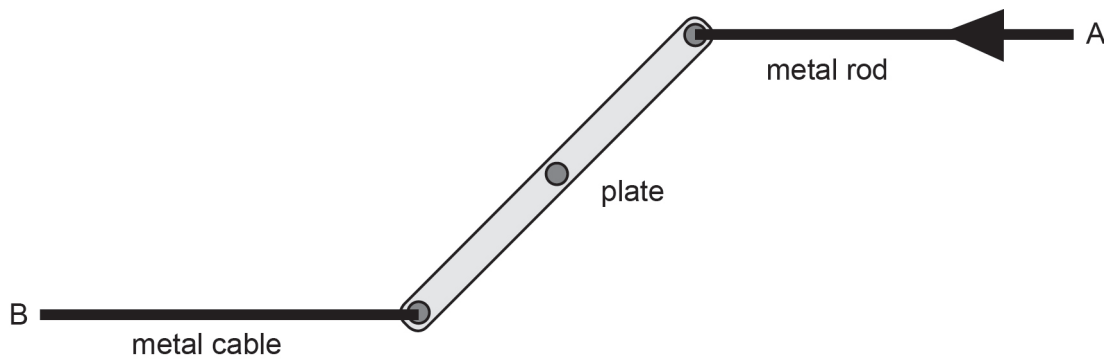

Which of the following is the magnitude of the force applied on the metal rod A?

- (a) 33 N
- (b) 133 N
- (c) 10 N
- (d) 100 N

Part B: Extended answer

50% (100 Marks)

This part has **five (5)** questions. Answer **all** questions. Write your answers in the spaces provided.

Spare pages are included at the end of this booklet. They can be used for planning your responses and/or as additional space if required to continue an answer.

- Planning: If you use the spare pages for planning, indicate this clearly at the top of the page.
- Continuing an answer: If you need to use the space to continue an answer, indicate in the original answer space where the answer is continued, i.e. give the page number. Fill in the number of the question that you are continuing to answer at the top of the page.

Question 38

(22 marks)

The diagram below shows a large tower crane commonly used on building sites. The main lift cable of this crane has a diameter of 20.0 mm and is made from steel. The horizontal boom is at a height of 40.0 m above the ground.

The crane is required to lift a load of 2.60 tonne at a point that is 30.0 m from the centre of the vertical support of the crane.

Cables A and B are support cables for the boom and Cable B is attached 30.0 m from the centre of the vertical support and makes an angle of 15° with the horizontal.

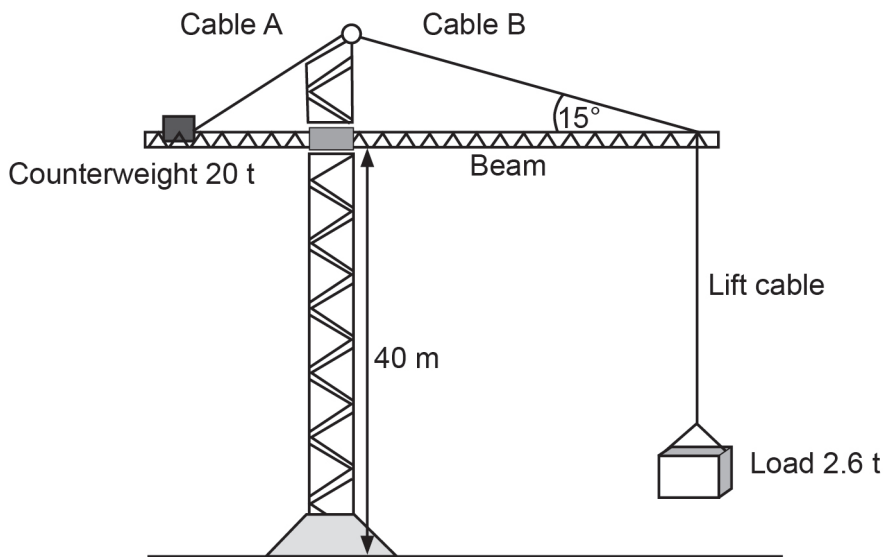

- (a) Using data from your **Data Book**, explain why the lifting cable is made from steel and not aluminium. (2 marks)

Question 38 (continued)

- (b) Calculate the tension in the lift cable when the 2.60 tonne mass is attached. Show **all** workings. (2 marks)

- (c) Ignoring the mass of the horizontal boom, how far from the centre of the vertical support must a 20.0 tonne counterweight be placed so that there is no net torque about the pivot? Note: If unsure of your answer to part (b) above, use 3×10^4 N. Show **all** workings. (2 marks)

- (d) If the steel cable used has an ultimate tensile strength of 400 N mm², determine the maximum mass that this cable can lift before it breaks. Note: If unsure of your answer to part (b) above, use 3×10^4 N. Show **all** workings. (5 marks)

- (e) Calculate the working stress for this cable at its maximum allowable load of 5.00 tonne. Show **all** workings. (2 marks)

- (f) Calculate the 'Factor of Safety' for this cable at its maximum allowable load. Show **all** workings. (2 marks)

- (g) Without shifting or altering the counterweight, or changing the cable, what could be done to lift a heavier weight with this crane? (1 mark)

- (h) Cable B connects to the boom at a point 30.0 m from the centre of the vertical support. Calculate the tension in Cable B when lifting the 2.60 tonne mass. Show **all** workings. (3 marks)

- (i) Determine the power rating of the lifting motor if it is 70.0% efficient and lifts the 2.60 tonne load to 25.0 m in 20.0 s. Show **all** workings. (3 marks)

Question 39

(17 marks)

The support cables to be used in the construction of a bridge are to be made from 50-strand multi-core stainless steel cable, with each strand having a diameter 2.52 mm.

Before it is manufactured, a single 2.50 m long strand of the cable is tested in a laboratory to determine its elasticity and yield stress. The following table gives the results obtained from this analysis and the extension of the single strand against the force applied to the end.

Force (N)	1000	1250	1500	1750	2000	2250	2650
Extension (mm)	2.5	3.2	3.9	4.6	5.1	5.7	8.3
Stress (kN mm ⁻²)	200	270	315	380	410	470	530
Strain ($\times 10^{-3}$)	1.0	1.28	1.56	1.84	2.04	2.28	2.58

These results have been used to draw the graph of stress versus strain provided on page 39.

- (a) 'The experimental yield stress for this sample was found to be 530 kN mm⁻²'. Explain what is meant by this statement. (1 mark)

- (b) Using the data in the table above, add the final point to the graph on page 39 and draw a line of best fit. (2 marks)

- (c) What is meant by the term 'toughness of a material'? How would you determine it from this graph? (2 marks)

Meaning: _____

How to determine: _____

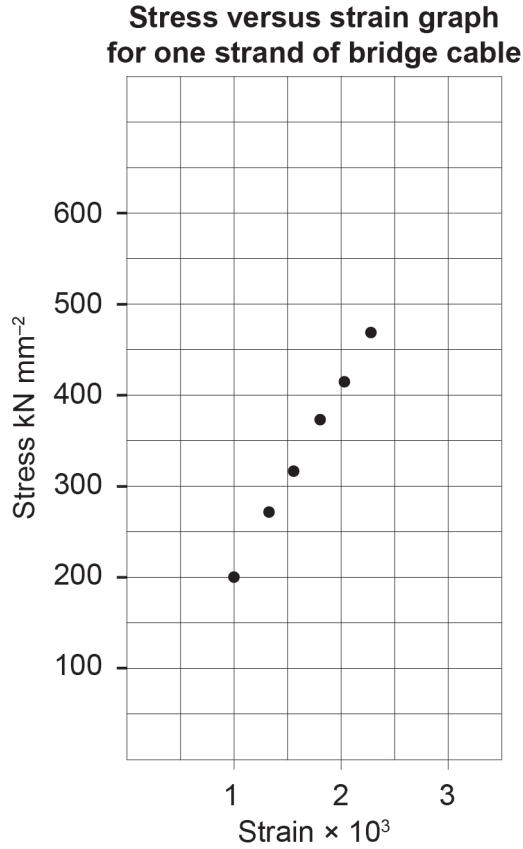

- (d) Calculate the gradient of the graph provided. Show **all** workings. (3 marks)

- (e) Explain how this value for gradient relates to the Young's modulus value for this cable. (1 mark)

Question 39 (continued)

- (f) What is meant by the term 'resilience of a material' and how would you determine it from this graph? (2 marks)

Meaning: _____

How to determine: _____

- (g) Use data obtained from your graph to determine by how much the length of this 2.50 m long single-strand sample of cable would increase under a stress of 250 kN mm^{-2} . Show **all** workings. (4 marks)

- (h) How would the value for Young's modulus obtained from this experiment be affected if a 50 core cable of the same length was used, instead of a single strand of the cable? Explain. (2 marks)

Question 40

(22 marks)

The arm of a remotely-controlled boom gate is 5.00 m long and made of uniform rectangular aluminium tube. It is pivoted from its left-hand end and supported at its right-hand end when closed, as shown in the diagram below.

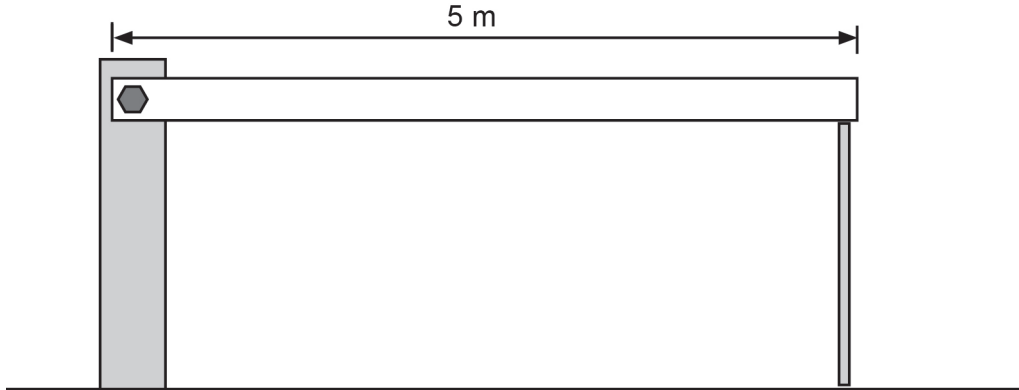

The external cross-sectional dimensions of the rectangular aluminium tube used are shown on the diagram below. The internal dimensions are 90 mm × 25 mm.

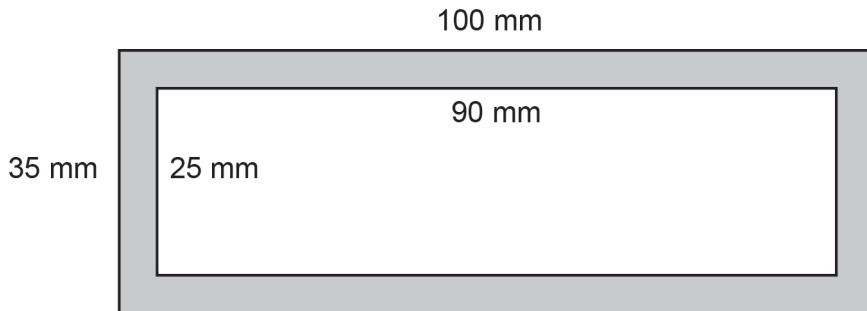

- (a) Calculate the volume of aluminium in the 5.00 m length of tube. Show **all** workings. (4 marks)

Question 40 (continued)

- (b) What is the mass in kilograms of this 5.00 m length of tube? Show **all** workings. (3 marks)

Note: If unsure of your answer to part (b) above, use a value of 18.0 kg for the mass of the boom when needed in the remainder of the question.

- (c) Using the equation $I_{xx} = \frac{(BH^3 - bh^3)}{12}$, calculate the second moment of area of this tube. Show **all** workings. (3 marks)

- (d) Using the relevant equation given in the **Data Book**, calculate the maximum deflection of the beam at its centre when supported at each end in the horizontal position. Show **all** workings. (4 marks)

If the electrical system to raise the gate fails, it can be lifted manually by using a special wrench to turn the gate at the pivot. This wrench is 80 cm long.

- (e) Calculate the minimum force that must be applied perpendicular to the handle of this wrench in order to lift the gate manually. Show **all** workings. (2 marks)

- (f) The lines below represent the length of the horizontal beam of the gate. Using these lines, draw labelled shear force and bending force diagrams for this beam when supported at both ends in the horizontal position. Indicate clearly the values of the forces at both the ends and the centre in terms of the total force F .

- (i) Shear force diagram: (3 marks)

- (ii) Bending moment diagram: (3 marks)

Question 41

(22 marks)

Poles that support above-ground electrical wires often have angled cables attached to the poles and connected to supports buried in the ground. The purpose of such cables is to stop the electrical wires from pulling the poles over. The diagram below represents one such pole with both the support cable and the electrical wire attached to its top. The horizontal component of the force exerted by the electrical wire on the vertical pole is 8500 N.

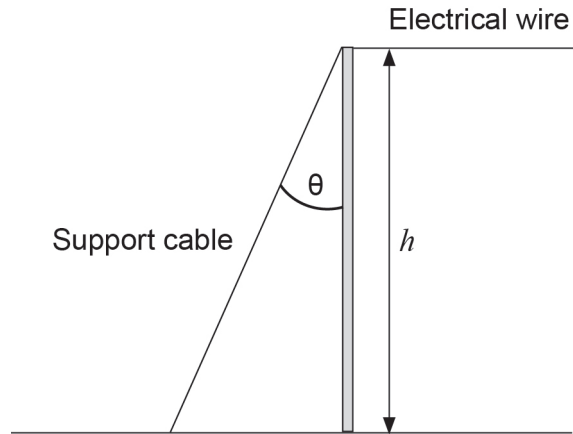

- (a) Explain how the support cable helps to prevent the pole from being pulled over. (1 mark)

- (b) List the **three** conditions required for this structure to be in equilibrium. (3 marks)

One: _____

Two: _____

Three: _____

- (c) Draw a labelled force diagram for the top of this structure showing all the relevant forces. (2 marks)

- (d) Calculate the tension in the support cable needed to balance the horizontal component of the force caused by the electrical wire, if the height $h = 18$ m and the angle θ that the support cable makes with the pole is 36.87° . Show **all** workings (3 marks)

The tension in the support cable exerts a downward force on the pole, creating stress.

- (e) Calculate the vertical component of the tension in the support cable. Show **all** workings. (3 marks)

- (f) Calculate the stress in the pole created by the support cable. Show **all** workings. (5 marks)

Question 41 (continued)

By considering factors such as density, electrical conductivity, thermal conductivity, tensile strength, yield stress, cost and corrosion resistance, choose the metal from those listed in your **Data Book** best suited for use in:

- (g) the electrical cable. Justify your answer. (3 marks)

- (h) the support cable. Justify your answer. (2 marks)

Question 42

(17 marks)

An engineer is test firing a projectile of mass 110 kg that is launched vertically upward and must reach a maximum height of 5.00 km in order to obtain low-altitude weather data.

Unless otherwise stated, you are to ignore air resistance in your calculations.

- (a) How much potential energy would the projectile gain when it reached its maximum height? Show **all** workings. (2 marks)

- (b) Calculate the minimum kinetic energy that the projectile would need at launch in order to achieve its maximum height. (1 mark)

- (c) Calculate the minimum initial launch velocity required for the projectile to achieve its maximum height. Show **all** workings. (3 marks)

Note: If unsure of your answer to part (c) above, use 310 m s^{-1} for the launch velocity in any remaining parts of this question.

- (d) Under these conditions, how long would it take the projectile to reach its maximum height of 5.00 km? Show **all** workings. (2 marks)

Question 42 (continued)

- (e) How much work is done on the projectile to enable it to reach its maximum height? Show **all** workings. (2 marks)

Note: If unsure of your answer to part (e) above, use a value of 5.50×10^6 J for the work done where required in any remaining parts of this question.

- (f) If the launch velocity was 340 m s^{-1} , in theory, what height would the projectile reach? Show **all** workings. (2 marks)

Air resistance and other factors result in the energy efficiency of this system being 40%.

- (g) How much work is actually done by the motor of the projectile to lift it to its maximum height? Show **all** workings. (3 marks)

- (h) Calculate the power of the projectile motor under these conditions. Show **all** workings. (2 marks)

End of Section Two: Mechanical

See next page

Section Two: Specialist field—Electronic/Electrical**60% (110 Marks)**

This section has **two (2)** parts.

Part A: Multiple-choice Answer **all** questions

Part B: Extended answer Answer **all** questions

Suggested working time: 110 minutes.

Part A: Multiple-choice**10% (10 Marks)**

This part has **10** questions. Answer **all** questions on the separate Multiple-choice Answer Sheet provided. For each question, shade the box to indicate your answer. Use only a blue or black pen to shade the boxes. If you make a mistake, place a cross through that square, then shade your new answer. Do not erase or use correction fluid/tape. Marks will not be deducted for incorrect answers. No marks will be given if more than one answer is completed for any question.

43. A soldering iron **most** suitable for soldering integrated circuits into a single-sided printed circuit board would preferably have a power rating
- of more than 60 W.
 - of less than 30 W.
 - that allows a maximum tip temperature of 180 °C.
 - that allows the tip temperature to exceed 500 °C.
44. A DPDT switch would have
- two connections.
 - four connections.
 - six connections.
 - eight connections.
45. Consider Circuits A and B below. What would be the behaviour of the circuits?

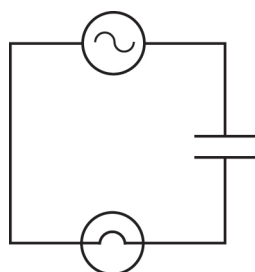

Circuit A

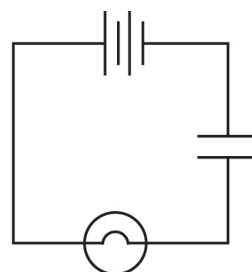

Circuit B

- The globe in Circuit A glows continuously, but the globe in Circuit B does not.
- The globe in Circuit B glows continuously, but the globe in Circuit A does not.
- Neither globe in Circuit A or B will glow continuously.
- Both globes in Circuit A and B will glow continuously.

See next page

46. A ceramic disc capacitor marked with the numbers '224' would have a capacitance of
- (a) 224 pF.
 - (b) 224 nF.
 - (c) 2200 nF.
 - (d) 0.22 μ F.
47. A circuit is required to switch a current of 1 A with an input of 750 μ A. The **most** suitable device would be a
- (a) bipolar transistor.
 - (b) very large magnetic relay.
 - (c) Darlington transistor.
 - (d) diode rated above 1 A.
48. When measuring current in a collector circuit
- (a) an ammeter should be used in series between the load and the collector.
 - (b) a voltmeter should be used in series with the collector and the load.
 - (c) a clamp-meter should be used between the base and collector.
 - (d) an ammeter should be used across the emitter and the collector.
49. If the collector current of a transistor with a h_{FE} of 40 is 0.12 A, what is the base current?
- (a) 30 mA
 - (b) 4.8 A
 - (c) 39.88 μ A
 - (d) 3 mA
50. A transformer is an inductive device that operates
- (a) only on DC.
 - (b) only on AC.
 - (c) on both AC and DC.
 - (d) only on 50 Hz.
51. What is the cost of running a 400 W swimming pool pump continuously for 5 days if the cost of 1 kWh of electricity is 24 cents?
- (a) \$4.80
 - (b) 48c
 - (c) \$11.52
 - (d) \$9.60

52. When using electrolytic capacitors in circuits, care should be taken to avoid using capacitors
- (a) whose capacitance exceeds the required capacitance by more than 5%.
 - (b) whose capacitance is less than the required capacitance by more than 5%.
 - (c) that exceed the required voltage rating.
 - (d) having less than the required voltage rating.

Part B: Extended answer

50% (100 Marks)

This part has **five (5)** questions. Answer **all** questions. Write your answers in the spaces provided.

Spare pages are included at the end of this booklet. They can be used for planning your responses and/or as additional space if required to continue an answer.

- Planning: If you use the spare pages for planning, indicate this clearly at the top of the page.
- Continuing an answer: If you need to use the space to continue an answer, indicate in the original answer space where the answer is continued, i.e. give the page number. Fill in the number of the question that you are continuing to answer at the top of the page.

Suggested working time: 110 minutes.

Question 53

(20 marks)

Answer the following questions about Circuits A and B, as shown in the diagrams below.

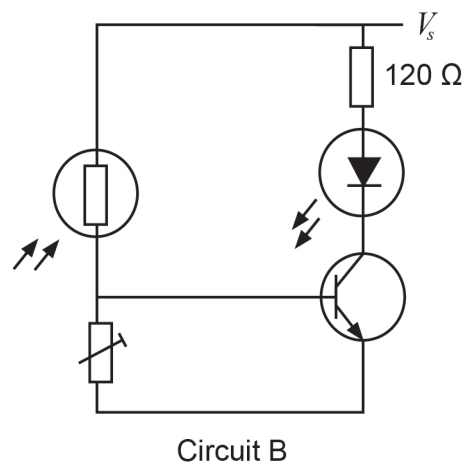
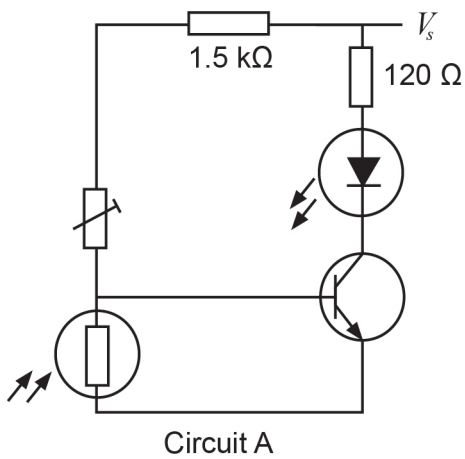

- (a) State the purpose of the $1.5\text{ k}\Omega$ resistor in Circuit A. (1 mark)

- (b) State the purpose of the variable resistor in Circuit A. (1 mark)

- (c) Circuits A and B are designed to operate in different ways. Describe the difference. (4 marks)

- (d) The LEDs in both Circuit A and B are super-bright white LEDs that are designed to operate at 3.3 V and draw a current of 60 mA. Assuming that the transistor is saturated and V_{CE} is 0, what voltage should be applied at $+V_s$? Show **all** workings. (5 marks)

Question 53 (continued)

- (e) When these circuits were constructed with $\frac{1}{4}$ watt resistors, one of the resistors in each circuit became extremely hot. Which resistor was the problem, and why did it become hot? (3 marks)

Resistor: _____

Why: _____

- (f) Redesign one of the circuits on page 52 to enable it to operate at dusk, switching a 12 V, 5 A light. You have been given a 12 V car battery, and a large quantity of common components, including a relay with the following characteristics:

coil operating voltage	6 V
coil operating current	60 mA
maximum switching voltage	24 V
maximum switching current	10 A.

(6 marks)

Question 54

(20 marks)

In electrofishing, fish are stunned by putting high voltage current into rivers or streams. The fish are actually attracted to the anode (or positive electrode) and when they swim close enough, they are stunned for several minutes and float to the surface. The fish are then netted and can be released later, suffering no long-term effects. The technique requires enough voltage to stun the fish but not enough to kill them. The conductivity of the water determines the appropriate voltage. Voltages used can be alternating current, pulsed direct current or smoothed direct current.

The diagram below shows a typical situation in which a generator is placed in a boat and connected to a very large copper cathode and a hoop-shaped stainless steel anode. Current flows through the water between the anode and cathode, but also through the water and along the more conductive river bed.

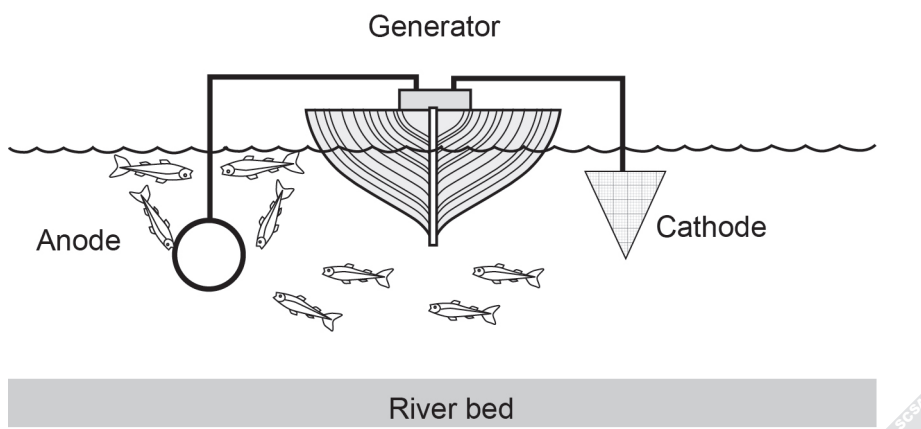

The circuit diagram for an electrofishing activity can look like this.

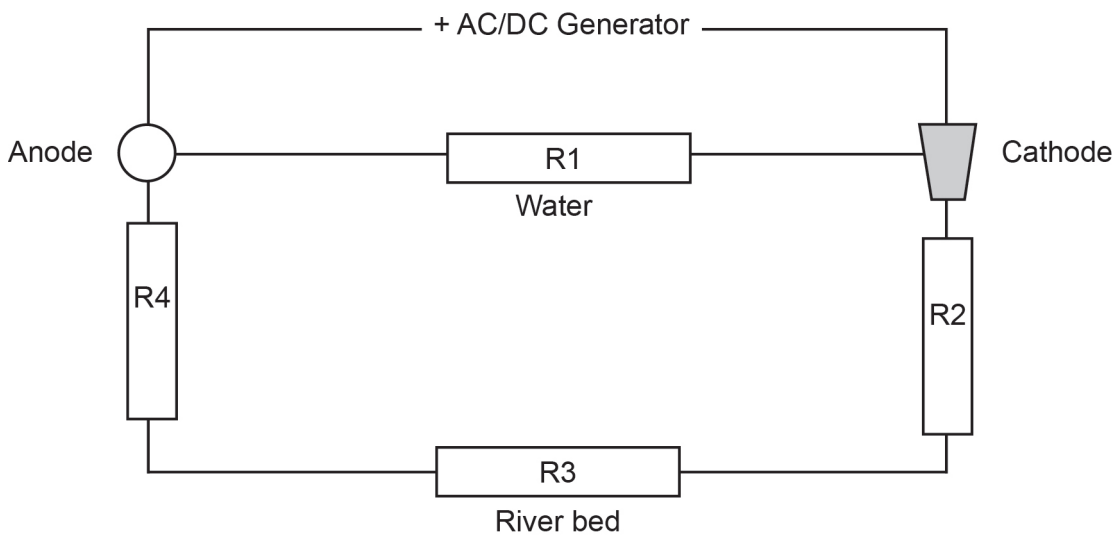

In the above circuit, the voltage is 300 V DC pulsed at 1 second intervals. R1 is 200 Ω, R2 is 160 Ω, R3 is 70 Ω and R4 is 170 Ω.

Question 54 (continued)

- (a) Draw a wave form to show what the voltage between the anode and cathode would look like. (3 marks)

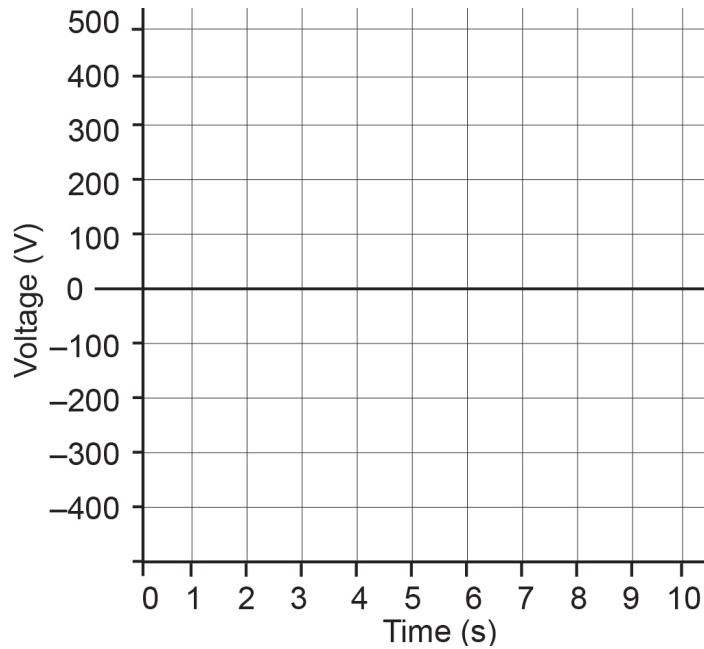

- (b) Determine the current that flows in the circuit. Show **all** workings. (3 marks)

- (c) Determine the voltage across the river bed (R3). Show **all** workings. (6 marks)

In the electrofishing circuit shown on page 55, the high resistance of the water prevented any fish being stunned, so the voltage applied to the electrodes was increased to 1kV AC at 100 Hz.

- (d) Draw a wave form to show what the voltage would look like. (3 marks)

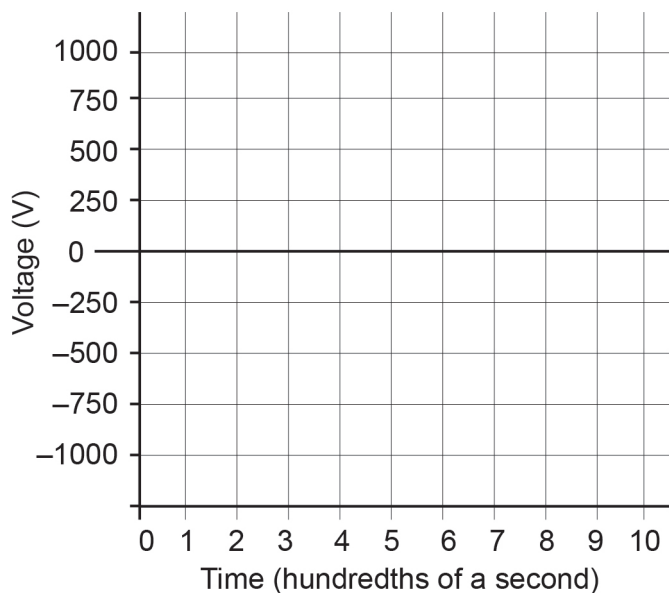

- (e) Calculate the power provided by the generator. Show **all** workings. (5 marks)

Question 55

(20 marks)

(a) Consider the power supply circuit diagram below.

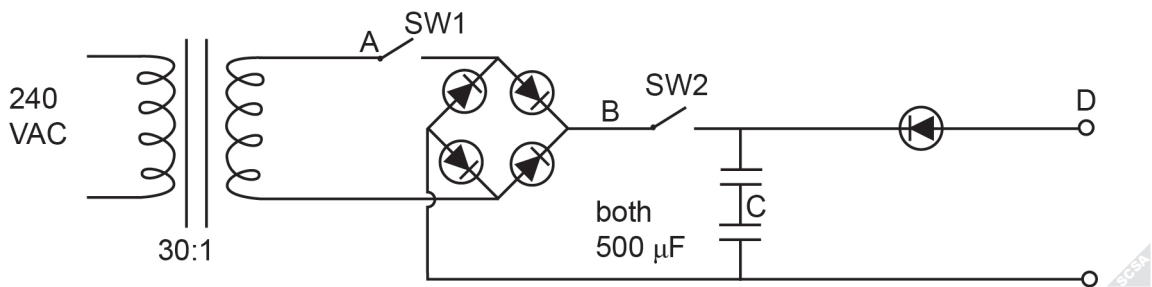

(i) State the voltage and polarity at Point A. (2 marks)

Voltage: _____ Polarity: _____

(ii) With SW1 closed, state the voltage and polarity at Point B. (2 marks)

Voltage: _____ Polarity: _____

(iii) With both SW1 and SW2 closed, state the voltage at Point C. (1 mark)

(iv) With both SW1 and SW2 closed, state the polarity at Point C relative to SW2. (1 mark)

(v) With both SW1 and SW2 closed, what is the voltage at Point D? (1 mark)

(b) Redraw the circuit above using a 240 V to 6 V transformer with full wave rectification and capacitance filtering. On the output use a voltage dropping resistor to operate an mp3 player that requires 2.8 V DC at 50 mA. Select a resistor closest to the preferred value. (6 marks)

(c) Two common methods of protecting circuits from reverse polarity are shown below.

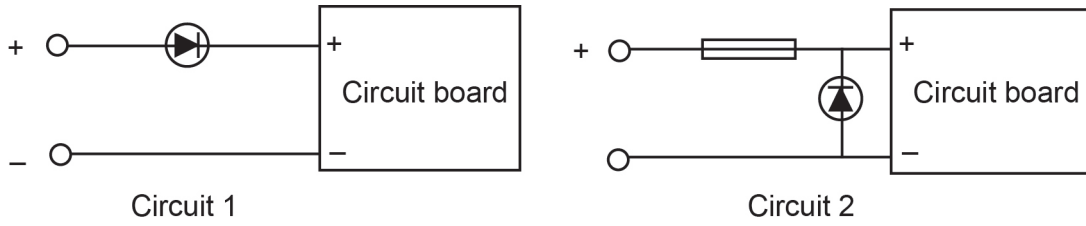

(i) Describe what happens when the supply voltage is reversed accidentally in Circuit 1. (2 marks)

(ii) What is the disadvantage of this protection circuit? (1 mark)

(iii) Describe what happens when the supply voltage is reversed accidentally in Circuit 2. (2 marks)

(iv) List **one** advantage and **one** disadvantage of the protection circuit in Circuit 2. (2 marks)

Advantage: _____

Disadvantage: _____

Question 56

(20 marks)

A farmer uses four solar panels to pump water from his dam to a distant water tank. The solar panels are rated at 27 V at 4 A under load and in full sunlight. The pump requires 48–56 V at 5 A to move the water to the distant tank.

- (a) Draw lines to show the connections that should be made below. Include a simple switch to isolate the motor at night and a 10 A fuse in your connections. (6 marks)

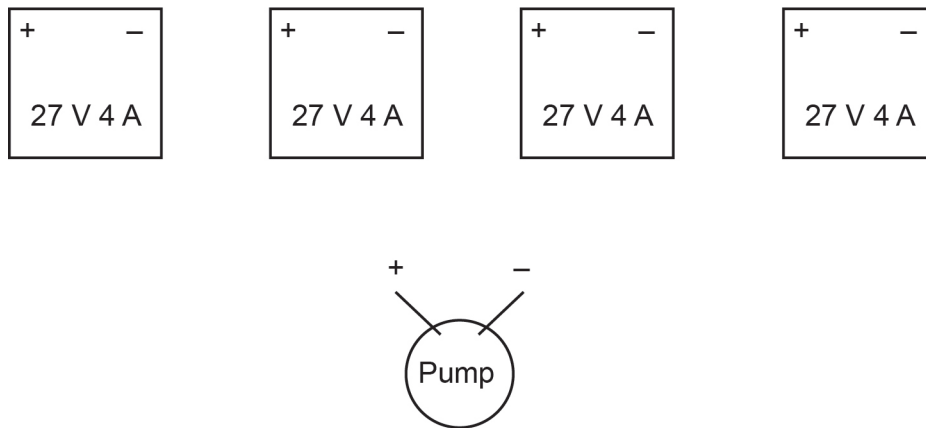

- (b) On cloudy days, the circuit below assists the solar panels by switching in a 52 V battery bank. The battery bank is kept charged from the solar panels when there is excess current available. The circuit monitors the cloud cover with an LDR and switches in the battery bank to increase the current to the pump only when necessary.

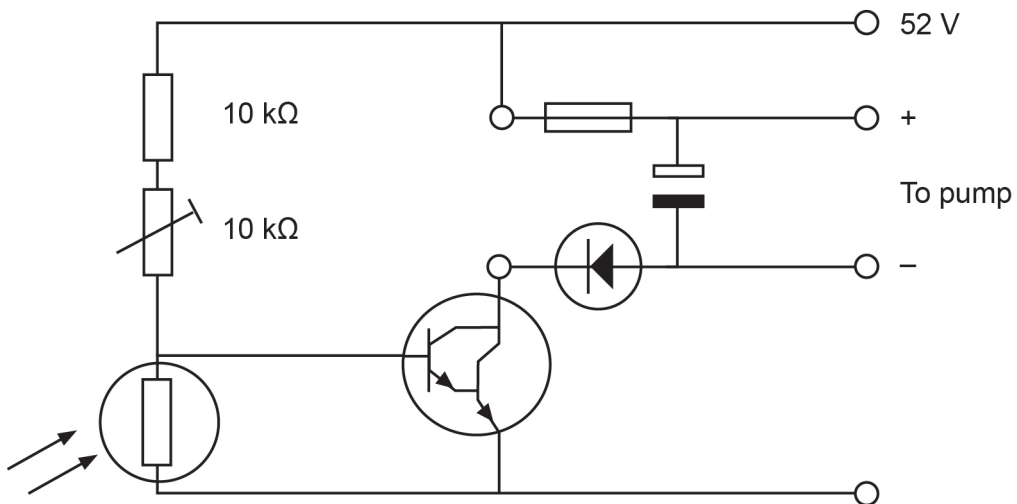

- (i) Determine the minimum voltage required across the LDR for the circuit to operate. (1 mark)

- (ii) If the variable resistor has a resistance of $6\text{ k}\Omega$ and the cloud cover causes the LDR resistance to increase to $450\ \Omega$, will the circuit operate? Prove your answer with calculations. (4 marks)

- (iii) The LDR now has a resistance of $500\ \Omega$ and the variable resistor is adjusted to a value of $7.5\text{ k}\Omega$. If the gain of the Darlington pair is 1500, what current is likely to be available to assist the solar panels to power the pump? Show **all** workings. (6 marks)

Question 56 (continued)

- (c) A resistor with the colour bands brown, grey, brown, silver is connected in parallel with a resistor with the colour bands orange, white, brown, gold. What is the maximum resistance from this combination? (3 marks)

Question 57

(20 marks)

The electrical circuit shown below is typical of that used in many motorcycles produced over the last sixty years. The circuit shown has a 12 V battery, switches have been numbered and fuses given alphabetical letters.

All the following questions relate to the motorcycle electrical circuit.

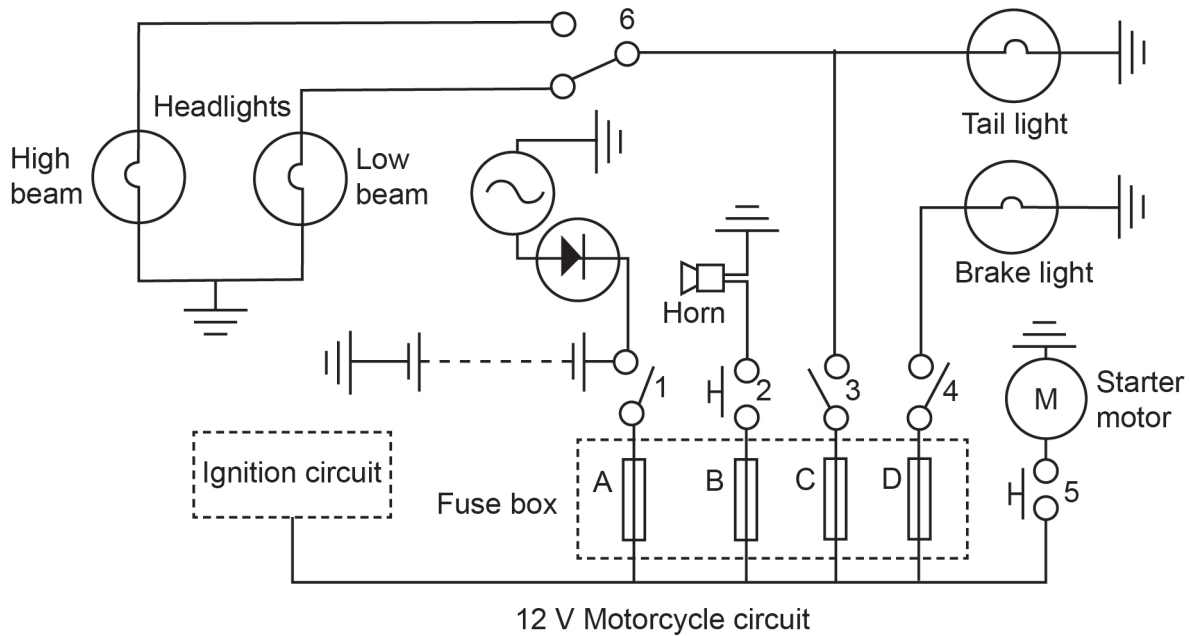

- (a) The fuse box shows four fuses. Which fuse must have the highest amperage rating? Why? (2 marks)

- (b) Which switches must be used in order to turn on the high beam headlight? (2 marks)

Question 57 (continued)

- (c) To start the motorcycle, the starter motor and ignition circuit must be powered. Which switch or switches must be used for this purpose? (1 mark)

- (d) If the horn fails to operate, list **three** possible faults that could cause the problem. (3 marks)

One: _____

Two: _____

Three: _____

- (e) The chart below shows the current drawn by different parts of the electrical circuit.

Circuit	Current
high beam headlight	5 A
low beam headlight	3.5 A
tail light	1.5 A
brake light	2 A
ignition circuit	2.4 A
horn	1.5 A

- (i) When the motorcycle is running and the starter motor is not engaged, calculate the maximum current that can be drawn from the battery. (2 marks)

- (ii) Determine the resistance of the tail light bulb. (1 mark)

- (f) Using an ammeter and without cutting wires or removing the bulb, how could you measure the current drawn by the brake light? (2 marks)

- (g) How could the battery charging circuit be made more efficient? (1 mark)

- (h) The motorcycle manufacturer wants to add a blue 2.6 V, 20 mA LED to indicate when the high beam is on and a green 2.1 V, 30 mA LED to show that the ignition is on.

On the section of the circuit below, show how that could be done and include the values of any resistors used. (6 marks)

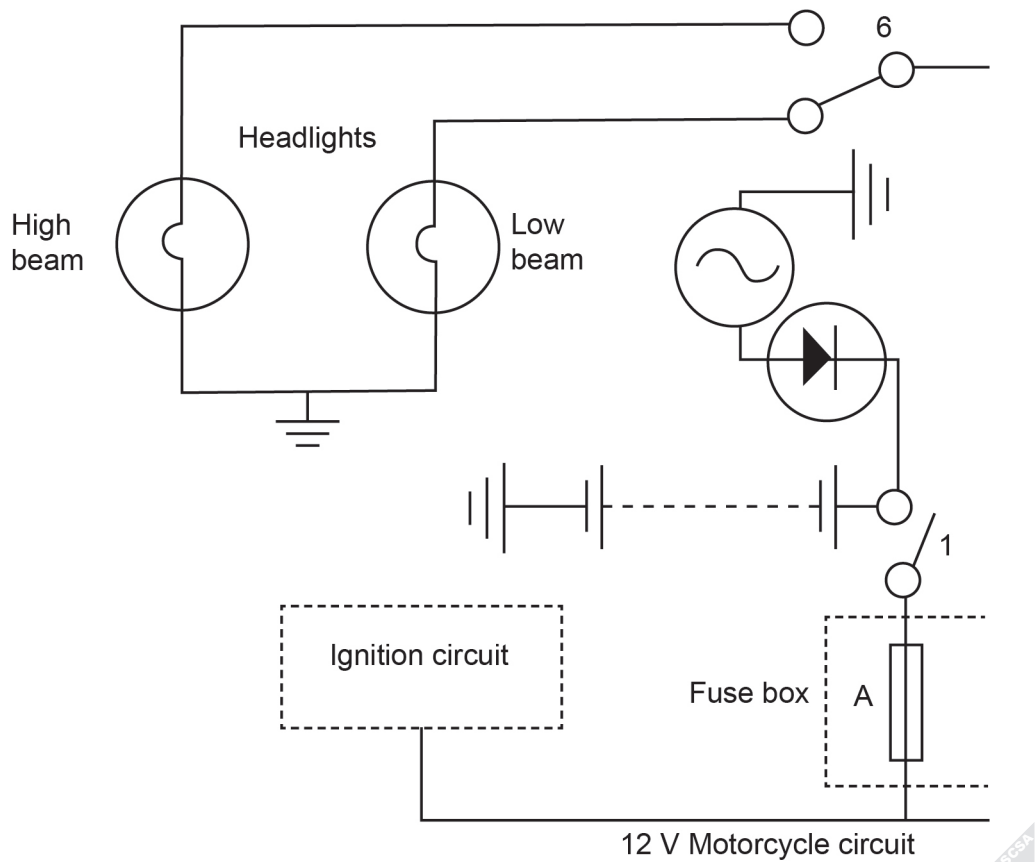

End of Section Two: Electronic/Electrical

End of questions

This document – apart from any third party copyright material contained in it – may be freely copied, or communicated on an intranet, for non-commercial purposes in educational institutions, provided that it is not changed and that the School Curriculum and Standards Authority is acknowledged as the copyright owner, and that the Authority's moral rights are not infringed.

Copying or communication for any other purpose can be done only within the terms of the *Copyright Act 1968* or with prior written permission of the School Curriculum and Standards Authority. Copying or communication of any third party copyright material can be done only within the terms of the *Copyright Act 1968* or with permission of the copyright owners.

Any content in this document that has been derived from the Australian Curriculum may be used under the terms of the Creative Commons Attribution-NonCommercial 3.0 Australia licence.

*Published by the School Curriculum and Standards Authority of Western Australia
303 Sevenoaks Street
CANNINGTON WA 6107*